



Minutes of Credition Town Council's Planning & Town Strategy Committee held on Tuesday 07 March 2023 at 19.00 at Old Landscore School, Greenway, Credition

Present: Cllrs E Brookes-Hocking, J Harris, J Downes, S Huxtable, J Cairney and N Letch

Apologies: Cllr D Ross

In Attendance: Emily Armitage, Administrative Officer
4 members of the public
Cllr G Fawssett in attendance
Cllr F Letch in attendance (part meeting)

133. To receive and accept apologies

The meeting was opened at 19.04.

It was **resolved** to receive and accept apologies from Cllr Ross. (Proposed by Cllr Cairney)

134. Declarations of Interest

Cllrs Cairney and Downes declared that as members of more than one authority, any views or opinions expressed at the meeting would be provisional and would not prejudice any views expressed at a meeting of another authority.

135. Public Question Time

Members of the public were present to discuss 23/00273/FULL. Cllr Brookes-Hocking requested they wait until item 9 to make comments.

136. To note that decisions will be made with the climate emergency at the forefront of decision and policy making

This was noted.

137. Order of Business

There were no changes.

138. Chairman's and Clerk's Announcements

There were no announcements.

139. Town Strategy Committee Minutes – To approve and sign the minutes of the Town Strategy Committee Meeting held on 07 February 2023, as a correct record

It was **resolved** to approve and sign the minutes of the meeting held on 07 February 2023.

(Proposed by Cllr Huxtable)

140. To receive a presentation by Jack Bostman from Jurassic Fibre (further information had been issued with agenda)

The presentation from Jurassic Fibre is attached to the minutes as appendix one.

Cllr N Letch asked whether there would be potential for employment in the area and suggested there would be a meeting held at Crediton Library which might be relevant. Cllr Brookes-Hocking enquired how much sponsorship they do. This will not be possible now until the new financial year commences, but they are open to communication and advised limited information could be found on social media and their website. It was agreed the Administrative Officer would investigate.

**141. Mid Devon District Council - Planning Applications [MDDC Planning Public Access Portal](#)
Mid Devon District Council, the determining Authority, has asked for comments from this
Town Council on the following planning applications:**

Ref: 23/00273/FULL

Proposal: Erection of children's home with associated amenity and parking

Location: Development Site at NGR 283549 100518 Newcombes, Crediton

Standing Orders were suspended to allow a member of the public to speak.

The member of the public summarised the concerns of the residents living in close proximity to the site, including the lack of information on the type of occupants intended and the lack of communication from the county council as to how the home/s would operate. Concern was expressed about the suitability of the location for children in care given the predominance of elderly residents nearby, who had already been disturbed by activities at the site during the evening.

It was **resolved** to recommend objection on the grounds of over-development of the site, loss of amenity space and car parking space and lack of biodiversity in the development. It was agreed for the application to be called in through Cllr F Letch as district and county councillor and to be put in touch with Children's Services. (Proposed by Cllr Brookes-Hocking)

Standing Orders were reinstated.

Ref: 22/00067/MFUL (Change of Description and Revised Drawings)

Proposal: Conversion of farmhouse and buildings to 17 dwellings, the erection of 14 dwellings and erection of 2 commercial buildings (Use Classes B8, E, Sui Generis)

Location: Wellparks, Exeter Road, Crediton, Devon

Councillors did not find it possible to open the 3D drawings or document relating to sections E, F & G so comments may be incomplete without this information from the application. Comments are based on other revised documents supplied.

There is a revised artist's impression - previously there were two, it would have been useful for see the revised impressions both updated.

Impact on the heritage asset

The link road, Well Parks Hill, on the east side of Well Parks House already negatively impacts the setting of the listed building. This is exacerbated by the proposal to introduce large-scale commercial buildings of an industrial and utilitarian appearance to the northeast of the asset and higher up the hillside. These will be visible across the valley.

The commercial units at 6.5m to the eaves appear excessively high and out of context for their surroundings, and as a result not the entrance to Crediton one would look for in accordance with the Local Plan. Well Parks Hill is at the entrance to the town and the development of this gateway site needs to be carefully considered if the area is not to be a clutter of buildings in different styles, of varying architectural quality, in order to fulfil different purposes. As the area develops, it is having an even more negative impact on the setting of Downes House itself, increasing the impact of splitting of the estate from the home farm by the constructions of the link road several years ago. This further development is therefore contrary to Objective 1.5 and Policy D5 of the Crediton NP.

The orchard to the southeast of the site is a welcome introduction to the landscape but clarity should be provided on the open public space availability and accessibility as it is not clear from the Site Masterplan. Although the heritage asset is still standing, it has been severely compromised, first by the proximity of new housing on the northwest side, and now by the proposal to introduce further development even closer on the west, north and east sides, including the commercial buildings which will dwarf and conflict with the asset. Well Parks House will virtually disappear into this newly constructed townscape. It has not been treated in a way which allows it to retain its historic character and contribution to the town's heritage. This is contrary to objective 7.1 and Policy H1 of the Crediton NP. To mitigate the impact of development, the asset should be protected by retaining an adequate and appropriately landscaped buffer zone on as many sides as still possible in order to give it a distinct setting, and by ensuring that buildings beyond the buffer zone are appropriately designed to complement the asset.

Traffic and transport

The overall lack of visitor parking is a concern, especially given the problems residents face in Tarka View - there needs to be learning in addition to complying with local plan development management policies. Indeed, there is only one space allocated to no. 7 & 8 in the new development, with only one visitor space allocated. The issue of safety of the cars has not been addressed with no improvement on the visibility of the cars from the owners' properties as required in para 24 of Principle 6 - Security of Parking. Overall, there are only 3 visitor spaces allocated for 31 dwellings, falling short of the requirement for one visitor space per ten dwellings as set out in para 27 of Principle 8 - Provision of visitor spaces.

In the Addendum to the Transport Assessment 3.5 - 3.7 refers to the provision of parking in the commercial unit area, and suggests sixteen spaces are required in total, not up to sixteen spaces as written. The next paragraph, 3.7 then states that the provision of fourteen car parking spaces in the commercial area accords with the MDLP parking standards. However, if the calculation shows that at least sixteen spaces are required how does providing fourteen meet that requirement? The Addendum suggests that the requirement for the commercial units is a maximum, but clarity is needed as to why this is the case as LP3 DM8 simply tables it a "car parking standard" and it is unclear if by definition this is an expectation The car parking looks inadequate to deliver appropriate spaces for staff and customers alike. Using the logic above mentioned in 3.7 suggests that zero parking would be appropriate.

The virtual footpath alongside the revised two-way road system appears to have been removed without mention and it is not obvious how the residents can safely exit the development on foot. The two-way road appears to be inadequate in width to accommodate two-way flow +

pedestrians and we question if this has been reviewed and commented on from a safety perspective.

Reference is made in the TA 3.15 of there not being a need to revisit the swept path analysis for the three new houses proposed, but this is required as there is nothing in the earlier TA showing how a refuse vehicle would manoeuvre safely collecting refuse from the newly introduced refuse storage area.

The refuse collection point and area for cycles in the area for the proposed Evelyn new homes requires more information as to how the cycles will be kept secure - it would be useful to know what the dotted line rectangles with a black line in the centre are depicting on the Site Masterplan please.

There is no mention of the provision of cabling for electric cars in the revised documents, this is a requirement of para 31 of Principle 11 - Electric Vehicle charging points requiring clarity as is the positioning of the residential electric charging points rather than providing a "generalisation". Therefore, as per 3.14 of the Addendum to the Transport Assessment the layout does NOT accord with MDLP standards.

It was **resolved** to recommend objection as the plans will have a negative impact on the setting of the heritage asset Wellparks House contrary to Policy H1 of the Crediton NP and will negatively impact the gateway entrance to the town, contrary to Policy D5 of the NP. (Proposed by Cllr Brookes-Hocking)

Ref: 22/00068/LBC (Change of Description and Revised Drawings)

Proposal: Listed Building Consent for conversion of farmhouse and buildings to 17 dwellings

Location: Wellparks, Exeter Road, Crediton, Devon

It was **resolved** to recommend objection as it is not clear that as many as possible of the features and character of the listed building will be preserved. The council noted that the previous Conservation Officer had expressed concerns and that the interim Conservation Officer had also identified where original features could be compromised. Given the very special nature of this asset, as expressed by English Heritage/Historic England, it was felt that there was a risk of features being lost by the developer failing to understand and respect the qualities of the original building. It being a historic asset, any re-development and re-purposing should clearly enhance the original. (Proposed by Cllr Brookes-Hocking)

Ref: 23/00282/HOUSE

Proposal: Erection of an office/study building

Location: West Park, Alexandra Road, Crediton

It was **resolved** to recommend no objection. (Proposed by Cllr Harris)

Ref: 23/00123/CAT

Proposal: Notification of intention to reduce the height of 1 Holly tree by 2m; removal of 1 Willow tree and remove all regrowth of 10 Yew trees within the Conservation Area

Location: 2 Union Terrace, Crediton, Devon

It was **resolved** to recommend approval as it is substantially overgrown. (Proposed by Cllr Harris)

Ref: 23/00331/TPO

Proposal: Application to lift the crowns of 7 Red Cedar trees to approximately 10-12m above ground level, and reduce the branches back from the property by 3-4m, protected by Tree Preservation Order 99/00007/TPO

Location: Woodland at NGR 282821 100674 Alexandra Road, CREDITON

It was **resolved** to recommend objection as the application states that the trees are not diseased or causing damage to the property, and no other reason for the crown lifting and pruning of branches has been given. CREDITON NP seeks to retain trees, Policy En2, as they contribute to the town's tree canopy and green corridors. However, if, in the opinion of the MDDC tree officer, this work is necessary and will not cause damage to or weaken the protected trees, such that their long-term future becomes compromised, the council will accept that advice. (Proposed by Cllr Harris)

142. Mid Devon District Council - Planning Decisions

Devon District Council, the determining Authority, has APPROVED the following applications with conditions as filed:

Ref: 22/01957/HOUSE

Proposal: Conversion of storage building to residential annexe and workshop

Location: 52 High Street, CREDITON, DEVON, EX17 3JX

Ref: 22/01959/LBC

Proposal: Listed Building Consent for conversion of storage building to residential annexe and workshop

Location: 52 High Street, CREDITON, DEVON, EX17 3JX

Ref: 23/00023/CAT

Proposal: Notification of intention to remove one Conifer, one Sycamore tree and remove 3m from height and shape one Beech tree within a Conservation Area

Location: Courtney Villa, High Street, CREDITON, DEVON

Ref: 22/02231/HOUSE (Revised drawings)

Proposal: Erection of 2 storey side extension

Location: 3 Albert Place, High Street, CREDITON, DEVON

Ref: 23/00111/CAT

Proposal: Notification of intention to remove one Leylandii tree within a Conservation Area

Location: Spinnakers, Four Mills Lane, CREDITON, DEVON

Ref: 23/00014/CAT

Proposal: Notification of intention to lift the crowns of 2 Yew trees and reduce the canopy of 1 Western Red Cedar tree within the Conservation Area

Location: 1 The Limes, East Street, CREDITON, DEVON

143. To note the email received from a member of public regarding the new car parking charges for Crediton and receive further information

The email was noted. Cllr Downes has raised an amendment to take this out of the budget. Parking charges will not increase this financial year.

144. To note the proposal for an 'Ark in the Park' and to agree any initial comments

Councillors noted the proposal and agreed that further discussion could be held after the May elections.

Standing Orders were suspended to allow a member of the public to speak.

Cllr F Letch commented that he had written to Andy Busby, Property Manager at MDDC regarding Newcombes Meadow and will give an update when more information is received. He advised that the proposal would need to go to consultation if agreed.

Standing Orders were reinstated.

145. To note that no comments had been received regarding the Silverton Neighbourhood Plan and no response had been sent to MDDC

Cllr Brookes-Hocking wished to congratulate Silverton Parish Council for completing the plan.

146. To note the response from MDDC on the Shared Prosperity Fund and the Rural England Prosperity Fund

The Administrative Officer advised she had received information from the Director of Place that a future meeting about these funds should be possible. It was agreed to attach the financial information Cllr Downes sent from MDDC to these minutes as appendix two.

147. To discuss the DCC amendment order ENV5966/15 (A) at Butt Parks

This was noted.

148. To discuss the planned work at Crediton telephone exchange

The Administrative Officer advised that the company propose to use RAL 7035 to all exposed concrete surfaces. As the site is adjacent to the conservation area and has strategic significance, it was **resolved** to suggest colour RAL 1015 to complement the street scene of white, cream and earth colours, which are identified in the Crediton Design Guide. It was also requested for the railings to be repainted, the repair of the 1953 stone plaque with the coronation crown on and the repainting of the front façade in its original colours. It was further agreed that some proper planting would improve the site. (Proposed by Cllr Brookes-Hocking)

149. To review the progress of Crediton Town Council Strategic Plan 2021-25

This has been updated and the plan will be continued with the same objectives.

150. To note the date of the next meeting – Tuesday 04 April 2023 at 19.00

The date of the next meeting was noted. The meeting was closed at 20.30.

Signed.....
(Chairman)

Date:.....

Ultrafast Crediton

7th March 2023

Presented by

Jack Böstman | Community Engagement Ambassador

Jack.Bostman@Jurassic-Fibre.com



About us

- Jurassic Fibre was formed in 2018.
 - Our state-of-the-art fibre network covers over 150,000 homes and businesses, and we plan to build to over 500,000 across the South-West by 2025.
 - Based in Exeter and Honiton, we now employ over 450 local people in local jobs.
 - Backed with an initial investment of £250m from Fern Trading (part of Octopus Investments).
- This year it was announced that Jurassic Fibre, along with all of Fern trading's other FTTP internet providers (Swish, AllPoints Fibre, Giganet and Cuckoo), will collaborate to form an integrated full-fibre network providing a greater reach to connect more communities together.

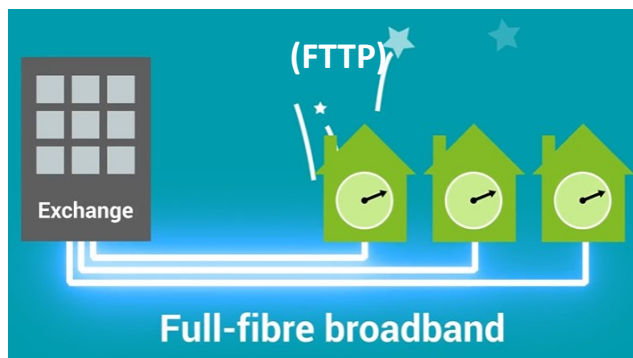
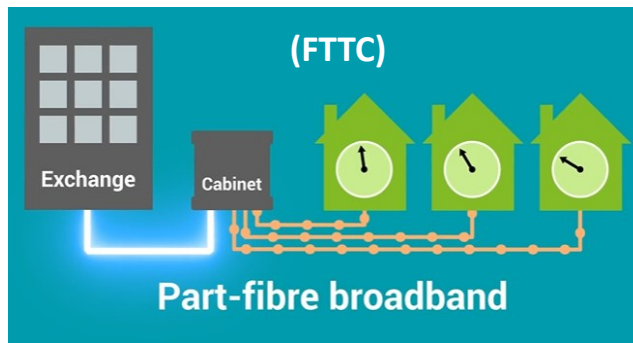
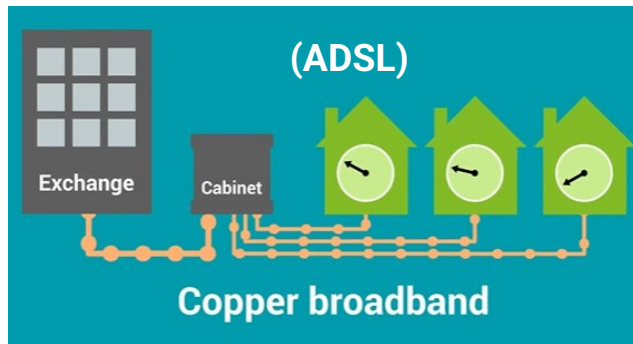

What is FTTP (Fibre-to-the-Premises)?

- Copper cables slow down speeds significantly and performance can be affected by factors such as:
 - The weather
 - Electrical interference
 - Distance from the exchange/cabinet
 - The number of users on the network
- Our ultrafast, Fibre-to-the-Premises (FTTP) network delivers:
 - Higher download speeds (up to 950 Mbps)
 - Faster connections (no more buffering)
 - Greater reliability
 - Futureproofing as the copper network will be retired in the future

Build Approach

- We build and manage our own state-of-the-art network 24/7.
- Our build methodology is based on creating core rings to join our PoP (Point of Presence) sites – our equivalent of a BT Exchange. This ensures complete resiliency across any part of our network.
- Our PoP Sites tend to be located in towns from which we build using an ‘inside-out’ type approach to firstly cover the town and continue to extend outwards into some of the hardest to reach and most rural locations.
- We currently have 30 live PoP sites, including Crediton, Sowton, Exmouth.
- Whilst we are deploying our own brand-new network, we extensively use existing poles and ducts wherever possible. This allows us to build quicker and with less disruption. However, there will still be occasions where a road closure will be required.

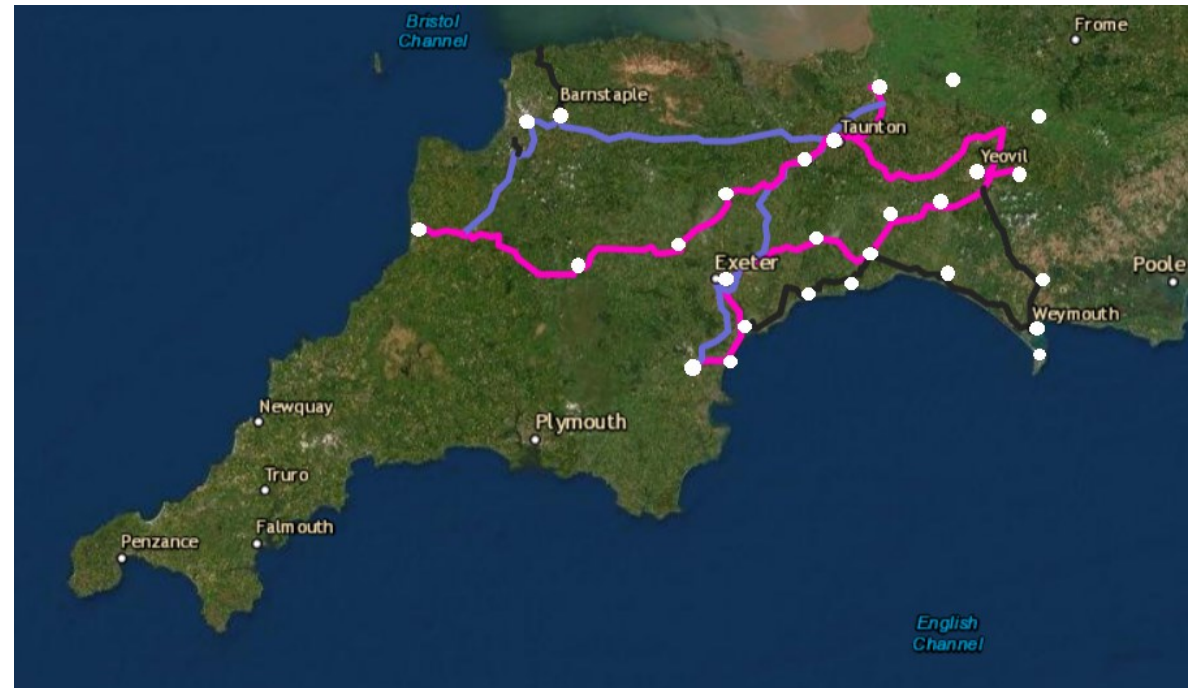

Jurassic Fibre Core Network and PoP Locations

Coverage in Crediton



- We are currently live in 1530 homes and businesses in Crediton, with plans to expand to another 1500+ premises.
- We will always consider requests for our network into areas where there is a lot of interest from local residents and businesses; one such area we are currently looking into is Newton St. Cyres.
- My role as Community Engagement Ambassador is to act as a point of liaison with residents in our build areas to answer any questions or concerns you may have and keep you up to date with progress.





Latest offers

- Unlike most Internet Service Providers, we offer a choice between a 2-year fixed price or a monthly rolling contract. This puts the customer at the heart of everything we do with no long-term commitment.
- Standard installation is free.
- Flexibility to change package at any time.
- VOIP (Voice Over Internet Protocol) phone packages also available. Users can port their existing landline number to this service for continuity.
- Speeds from 150 to 950 Mbps to help support in every aspect of life from homeworking to streaming to subscription services to online tools across a whole range of smart devices all at once!

Rolling Contract

SmartHome 150	SmartHome 450
150 Mb/s Average download speed Average upload speed: 30Mb/s	450 Mb/s Average download speed Average upload speed: 100Mb/s
 Monthly cost £30	 Monthly cost £40

Fixed price Contract

SmartHome 150	SmartHome 450	SmartHome 950
150 Mb/s Average download speed Average upload speed: 30Mb/s	450 Mb/s Average download speed Average upload speed: 100Mb/s	950 Mb/s Average download speed Average upload speed: 200Mb/s
 Monthly cost £22.50	 Monthly cost £25	 Monthly cost £40

Current planned roadworks within next three months

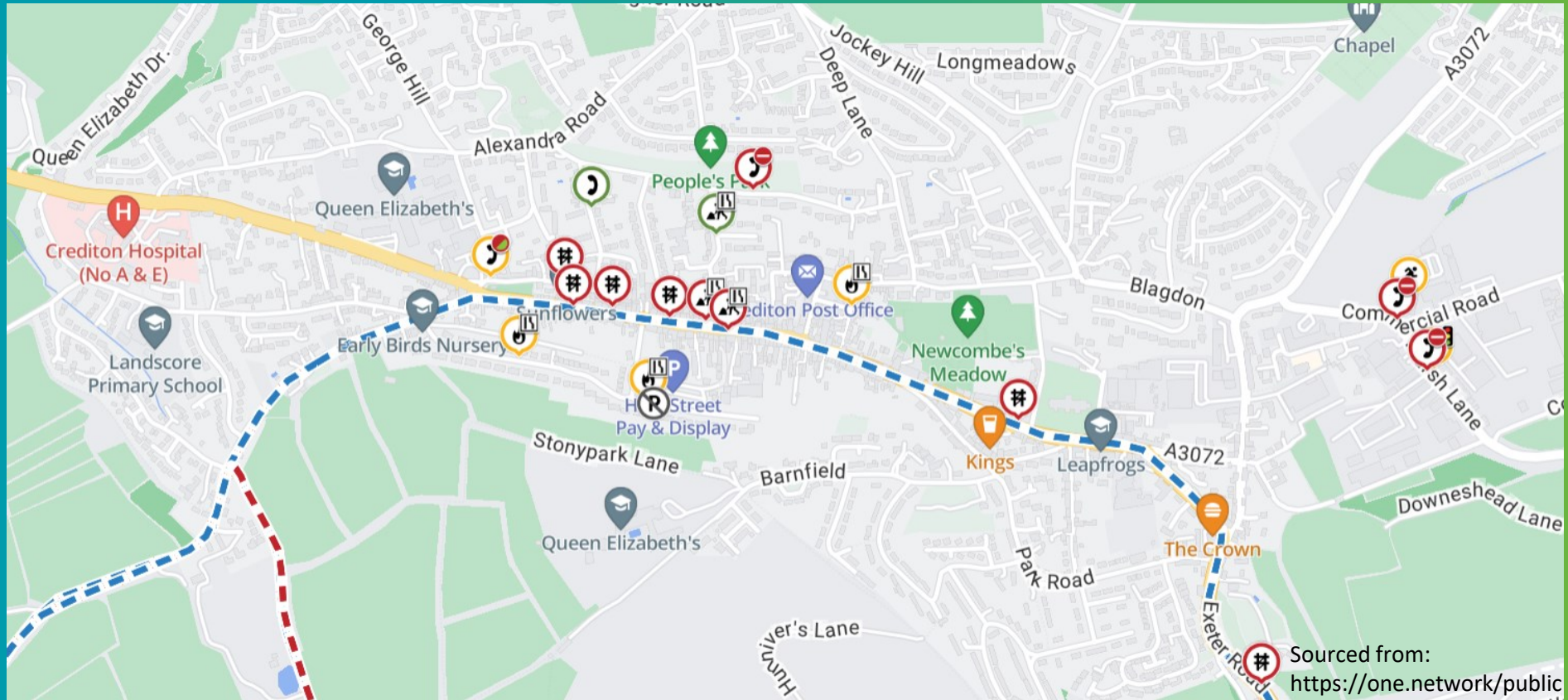

These symbols represent upcoming roadworks and who will implement them. The telephone icon refers to the approved permits submitted by Jurassic Fibre.

Business Broadband Packages

Package	Download Speed	Upload Speed	Monthly Price	24-Month Fixed Price
SmartBiz 100	100Mbps	20Mbps	£25	£36 thereafter*
SmartBiz 300	300Mbps	60Mbps	£35	£52 thereafter*
SmartBiz 500 (GREAT VALUE)	500Mbps	100Mbps	£40	£72 thereafter*
SmartBiz 950	950Mbps	200Mbps	£50	£99 thereafter*

- Speeds from 100 to 950 Mbps.
- Flexibility to change package at any time.
- All our sales and after-sales staff are based in Exeter. You will always be able to speak with a person.
- Highly competitive price packages against wholesale providers.
- 1 static IP address included



Working with the community

- Built by people in the South-West for people in the South-West.
- A huge investment for the future – over £120m spent so far. We are empowering the region infrastructure and connectivity it deserves. An economic and social boost.
- We are currently working with Exeter College to design programs addressing current skill shortages within the industry.
- Our first apprentice from our apprenticeship program has also recently joined the recruitment team.
- We sponsor multiple local charities and organizations all over Devon, Cornwall, Somerset and Dorset.
- Locally we are on the lookout for new sponsorship opportunities that are important to the people of Crediton and help support the community.



Register your interest

<https://Jurassic-Fibre.com>



Jurassic Fibre

Appendix A – Summary of SPF Interventions and Proposed REPF Interventions

SPF Investment Priority	SPF Interventions	Proposed REPF Interventions
Support for local start-ups and micro-businesses (SMEs)	Business Support £208,000	
Support the development of incubation and flexible work-space	Work Hub Development £182,000	Market Area Enhancements (£100,000)
Support for business innovation and adoption of modern processes and advanced technology by local start-ups and micro-businesses	Business Innovation Centre(s) – £213,000 Business Innovation and Technology Grants £118,000	(+ £50,000) Business Innovation Grants (+ £157,000)
Support a thriving agricultural sector that showcases field-to-fork practices and low food miles to market	Field to Fork initiatives £50,000	Field to Fork capital grants (£150,000)
Strengthening the Visitor Economy	Supporting the Visitor Economy £49,000	Supporting the Visitor Economy (+ £60,000) Sustainable Tourism capital grants (£150,000)
Revitalise our town centres by: <ul style="list-style-type: none"> Improving the public realm Supporting an improved retail offer Bringing vacant shops back into use Promoting a programme of events, festivals 	Love Your Town Centre £104,000	
		Supporting Community Businesses and Community Infrastructure (£150,000)

SPF Investment Priority	SPF Interventions	Proposed REPF Interventions
Increase the number of higher skilled, better paid jobs	Support for young people not in employment £50,000 Support for an Inclusive workforce £40,000 Support for upskilling workers in new skills for a new economy £50,000	
Total Investment	£1,064,000	£817,000